

# PDS-LCHB

Large Flat Panel Ceiling Mount - Head Only

## Product Features:

- Holds most 37" - 90" flat panels
- Maximum mounting hole pattern - 860mm x 500mm
- Rotates 360° / Adjustable 0° - 15° tilt
- Uses standard 1.5" NPT masting
- Load capacity - 180 lbs
- Black powder coat finish

## Product Specifications: *(for Architects & Engineers)*

The mounting head only portion of the ceiling mount shall be the Video Mount Products (VMP) part number PDS-LCHB. The mount shall be able to accommodate most 37" - 90" flat panels.

The mount shall be able to handle hole patterns up to 860mm wide and 500 mm tall. The mount shall be capable of rotating 360° and have a 0° to +15° tilt. The mount shall be capable of attaching to preexisting 1.5" NPT pipe or any VMP EXT-Series which is 1.5" NPT pipe. The mount shall have a weight capacity of 180 lbs. The mount shall have a black powder coat finish.

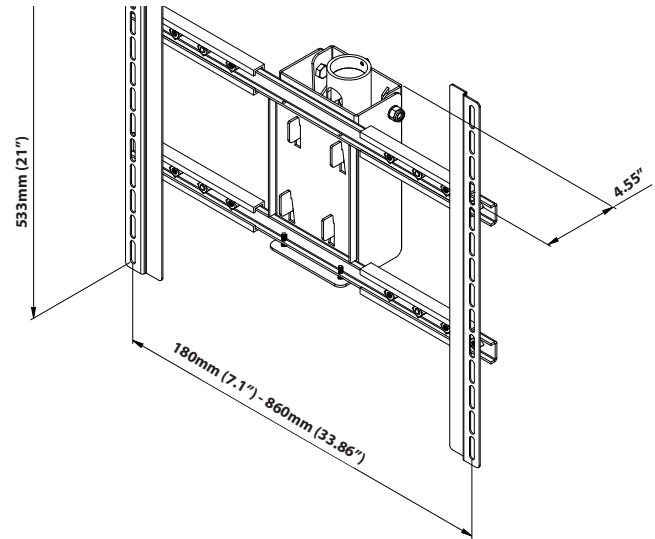

## Video Mount Products

345 Log Canoe Circle Stevensville, MD 21666  
Toll Free: 877.281.2169 Telephone: 410.643.6390  
Facsimile: 410.643.6615 [www.videomount.com](http://www.videomount.com)

