

ERWEN-F22E

19" Fixed Wall Equipment Rack Enclosure - 22U

Product Features:

Welded steel construction

Ships fully assembled

Overall Dimensions – 42.6"H x 23.6"W x 23.5"D

Usable Depth – 19.875"

Works with all standard 19" rack equipment and accessories

Rails have numbered spaces with standard 10-32 threading

Adjustable front and rear rails

Vented top and bottom

Top and bottom cable routing knockouts

Reversible hinged tempered glass front door

Removable locking side panels

Load capacity – 150 lbs

Black powder coat finish

Product Specifications:

(for Architects & Engineers)

The 22U (rack unit) wall mounted equipment rack enclosure shall be the Video Mount Products (VMP) ERWEN-F22E. The overall dimensions for the ERWEN-F22E are 42.6"H x 23.6"W x 23.5"D with a maximum useable depth of 19.875". The ERWEN-F22E shall work with all EIA compliant 19" rack equipment and accessories which are less than 19.375" in depth. The ERWEN-F22E shall come equipped with two sets of adjustable rack rails which are #10 32UNF threaded and have rack spaces numbered. The ERWEN-F22E shall come with a lockable, reversible tempered glass front door. The ERWEN-F22E shall have knock-out panel in the rear wall of the enclosure as well as mounting holes for wooden studs with 16" centers. The ERWEN-F22E shall have a vented top and bottom.

The ERWEN-F22E shall also have rear cable entry and exit points located on the top and bottom of the enclosure. The ERWEN-F22E shall have two mounting points for standard fans which can be purchased separately or as a kit (ERWEN-2FANKIT). The ERWEN-F22E shall have lockable removable side panels. The ERWEN-F22E shall have a load capacity of 150 lbs. The ERWEN-F22E shall be fully welded, and ship assembled. The ERWEN-F22E shall have a black powder coat finish.

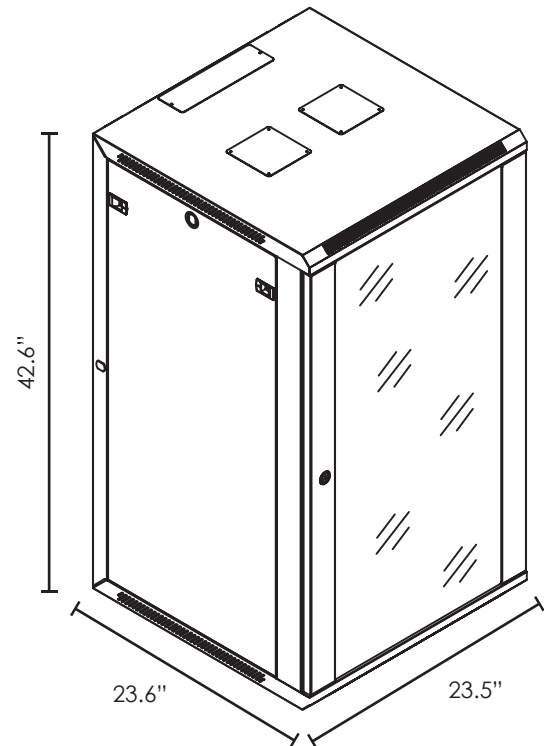

Video Mount Products

345 Log Canoe Circle Stevensville, MD 21666

Toll Free: 877.281.2169 Telephone: 410.643.6390

Facsimile: 410.643.6615 www.videomount.com

VMP
VIDEO MOUNT PRODUCTS