

FP-XLWAB

Large Flat Panel Articulating Wall Mount

Product Features:

- Holds most 42" – 90" flat panels
- Max VESA mounting hole pattern – 600mm x 400mm
- Min VESA mounting hole pattern – 200mm x 200mm
- Low profile depth – 2.8" (collapsed) to 25.3"(fully extended)
- Adjustable tilt - - 2° to ±10° / Rotates – ±45°
- List adjustment – ±3°
- Cable management system through arms
- Load capacity – 150 lbs
- Black powder coat finish

UL listed

Product Specifications:

(for Architects & Engineers)

The articulating wall mount for the 42" to 90" flat panel display shall be the Video Mount Products (VMP) FP-XLWAB.

The mount shall be designed to attach to 2 studs approximately 16" apart or other suitable support surface.

The mount shall be constructed primarily of formed steel and aluminum and shall incorporate arc welds. The mount shall be a universal style mount capable of adjusting to the dimensions of a variety of popular 42" to 90" flat panel displays and not be model specific. The adjustable mounting rails shall be capable of accommodating VESA mounting hole patterns ranging from 200mm x 200mm to 600mm x 400 mm. The mount shall have an adjustable distance from the wall that ranges between 2.8" to 25.3". The mount shall be capable of tilting from -2° to +10°. The mount shall incorporate post install level correction capability of ±3°. The mount shall have a UL Listed load capacity of 150 lbs. The mount shall come in a black powder coat finish.

Video Mount Products

345 Log Canoe Circle
Stevensville, MD 21666
Toll Free: 877.281.2169
Telephone: 410.643.6390
Facsimile: 410.643.6615
www.videomount.com

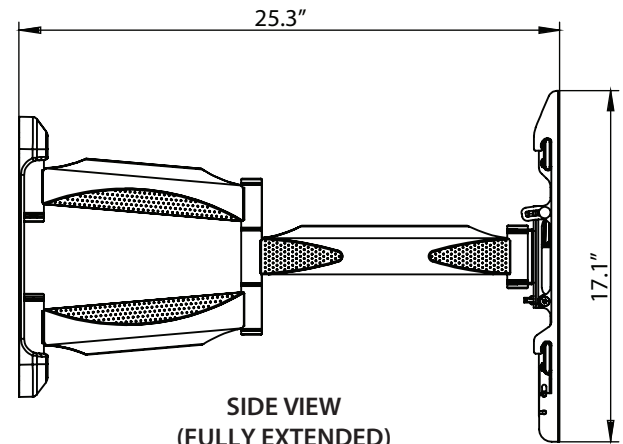

SIDE VIEW
(FULLY EXTENDED)

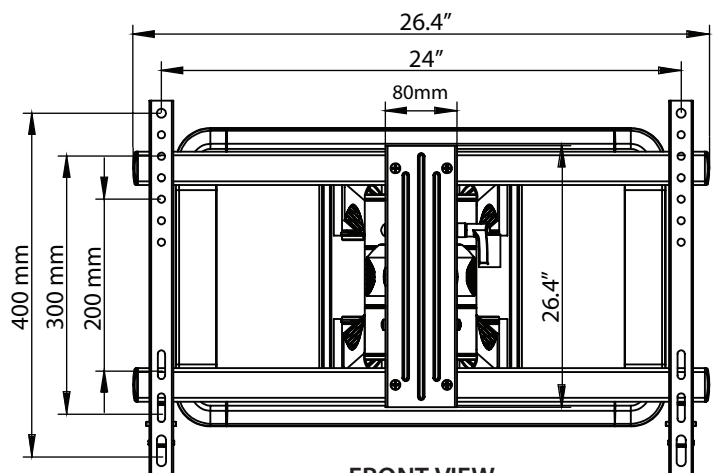

FRONT VIEW

VMP
VIDEO MOUNT PRODUCTS