

LCD-MID-CHB

Mid-Size Flat Panel Ceiling Mount - Head Only

Product Features:

Holds most 27" – 42" flat panels

Maximum flat panel hole pattern - 410mm x 340mm

Rotates 360° / Adjustable -5° to +20° tilt

Uses standard 1.5" NPT masting

Load capacity – 100 lbs

Black powder coat finish

Product Specifications:

(for Architects & Engineers)

The mounting head only portion of the ceiling mount shall be the Video Mount Products (VMP) part number LCD-MID-CHB. The mount shall be able to accommodate most 27" – 42" flat panels. The mount shall be able to handle hole patterns up to 410mm wide and 340 mm tall.

The mount shall be capable of rotating 360° and have a -5° to +20° tilt. The mount shall be capable of attaching to preexisting 1.5" NPT pipe or any VMP EXT-Series which is 1.5" NPT pipe. The mount shall have a weight capacity of 100 lbs. The mount shall have a black powder coat finish.

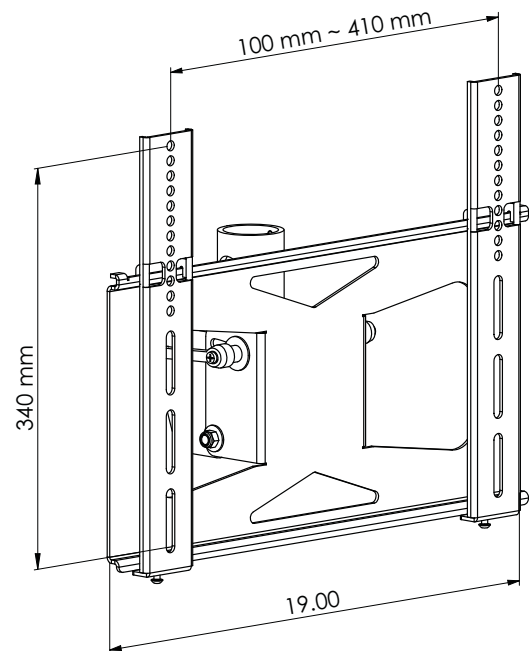

Video Mount Products

345 Log Canoe Circle

Stevensville, MD 21666

Toll Free: 877.281.2169

Telephone: 410.643.6390

Facsimile: 410.643.6615

www.videomount.com

VMP
VIDEO MOUNT PRODUCTS