

# **WMP**

VIDEO MOUNT PRODUCTS

*Instruction Sheet For:*

## **LCD-MID-CM2 & LCD-MID-CM2B**

---

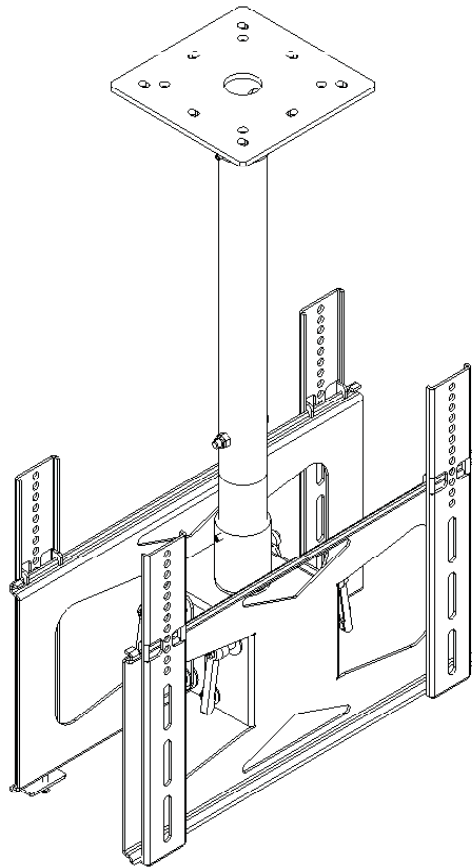

---

*For more information, please contact us at:*  
345 Log Canoe Circle, Stevensville, Maryland 21666  
Toll Free: 877.281.2169 Phone: 410.643.6390 Fax: 410.643.6615  
**[www.videomount.com](http://www.videomount.com)**

# LCD-MID-CM2

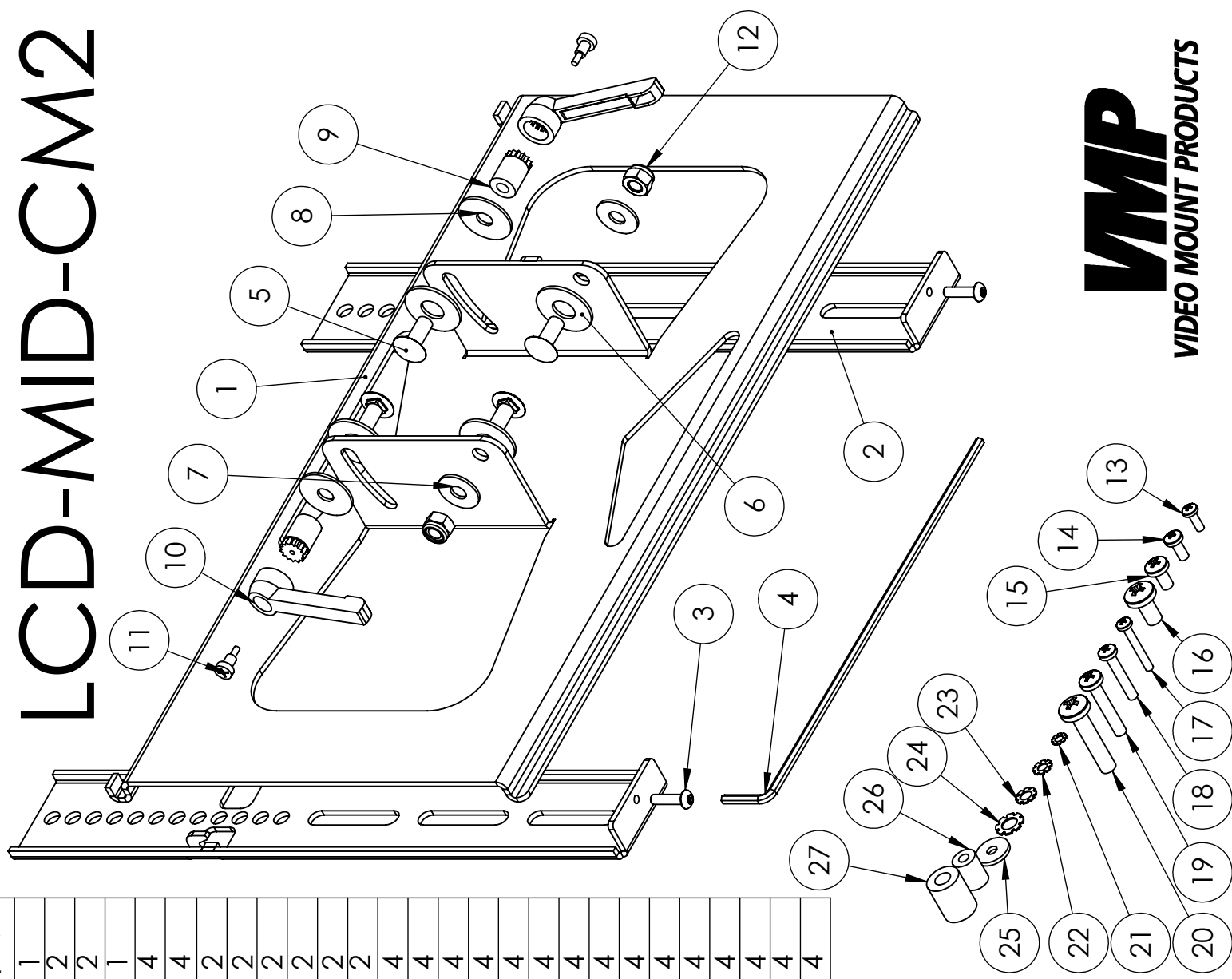

ITEM NO.	DESCRIPTION	QTY.
1	Tilt Plate	1
2	Screen Mounting Brackets	2
3	Security Screw M5*P0.8*L20	2
4	Long Allen Key M4	1
5	Carriage Screw M8*P1.25*L20	4
6	Nylon Washer $\phi$ 12.5* $\phi$ 30*T1.8	4
7	Washer $\phi$ 5/16"* $\phi$ 19*T1.6	2
8	Washer $\phi$ 8.5* $\phi$ 25*T2.0	2
9	Gear Nut	2
10	Lever Handle	2
11	Lever Screw	2
12	Nylon Nut M8*P1.25	2
13	Screw M4*P0.7*L12	4
14	Screw M5*P0.8*L12	4
15	Screw M6*P1.0*L12	4
16	Screw M8*P1.25*L16	4
17	Screw M4*P0.7*L30	4
18	Screw M5*P0.8*L30	4
19	Screw M6*P1.0*L35	4
20	Screw M8*P1.25*L40	4
21	Lock Washer M4	4
22	Lock Washer M5	4
23	Lock Washer M6	4
24	Lock Washer M8	4
25	Washer $\phi$ 5.5* $\phi$ 18*T2.0	4
26	Spacer M6	4
27	Spacer M8	4

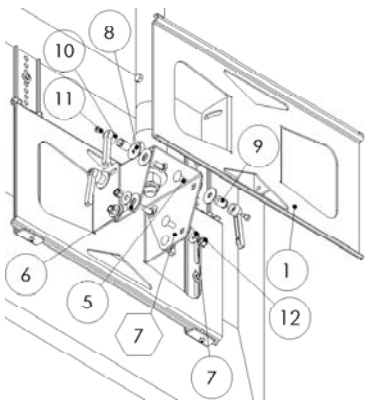

Step 2: Attaching the tilt plate

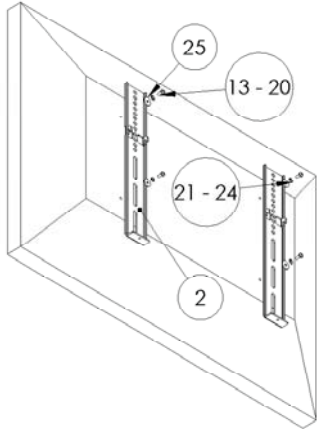

Step 3: Attaching the mounting brackets to the screen (spacers not needed)

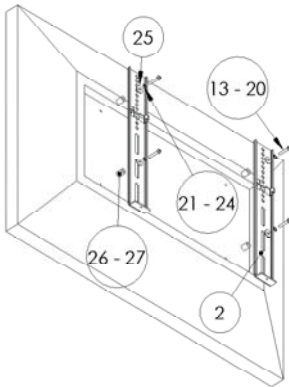

Step 3: Attaching the mounting brackets to the screen (spacers used due to recessed hole patterns)

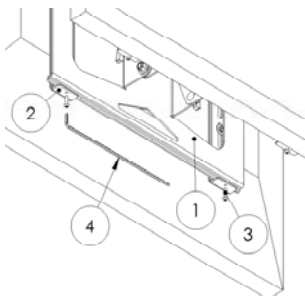

Step 4: Attaching the mounting brackets to the tilt plate

## Step 1

Before starting, lay out all parts to your mount and match them to the parts list provided. Verify that you have all your parts before attempting to assemble the mount. **Note: For the purposes of these instructions it is assumed you have assembled and mounted the LCD-MID-C. If you have not done so, then proceed to do so at this time. Note: For these instructions LCD-MID-C parts are labeled with hexagons and LCD-MID-CM2 parts are labeled with circles.**

## Step 2

Attach the tilt plate (1) LCD-MID-CM2 to the base plate (7) LCD-MID-C by first inserting plastic washers (6) LCD-MID-CM2 in between the base plate and tilt plate on each side. Then insert the 5/16" by 3/4" long square neck screws (5) LCD-MID-CM2 into the base plate (7) LCD-MID-C so the screws are pointed outwards. On the bottom screws on each side secure the screws with the 19 mm outer diameter washers (7) LCD-MID-CM2 and nylon nuts (12) LCD-MID-CM2. On the upper screws place the 25 mm outer diameter washers (1) LCD-MID-CM2 and use the gear nuts (1) LCD-MID-CM2, lever handle (10) LCD-MID-CM2 and lever screw (8) LCD-MID-CM2 to secure the tilt plate's (9) LCD-MID-CM2 position. Tilt the tilt plate (10) LCD-MID-CM2 as far up as it will go and lock the tilt into place by tightening down the lever handle (11) LCD-MID-CM2 as far as it will go on each side. **Note: This is important to do to allow step 4 to be accomplished safely and easily.**

## Step 3

Determine the correct screw size and if you need to use washers, lock washers, or spacers. **Note: Spacers are used for TVs with recessed hole patterns. Secure the display to the screen mounting brackets (2) LCD-MID-CM2 using the appropriate hardware (LCD-MID-CM2 (13) through (27)). Note: The brackets have to be level with each other to work properly.**

## Step 4

Make sure the tilt plate (1) LCD-MID-CM2 is locked into place by tightening down the lever handles (10) LCD-MID-CM2 as far as they will go. Lift the screen mounting brackets (2) LCD-MID-CM2 with the attached flat panel onto the tilt plate (1) LCD-MID-CM2. Then while another person is holding the flat screen in place tighten down the security screws (3) LCD-MID-CM2 as far as they will go with the long Allen key (4) LCD-MID-CM2 to lock the screen mounting brackets (2) LCD-MID-CM2 into place. Once the screen mounting brackets (2) LCD-MID-CM2 are secure then you can adjust the tilt by loosening the lever handles (10) LCD-MID-CM2 and adjusting the tilt plate (1) LCD-MID-CM2 to the desired position and then retightening the lever handles (10) LCD-MID-CM2 once it is in position. Please verify that all nuts and screws are securely tightened.

# Enjoy Your Mount!

**WARNING: The installer of these products must verify that the mount surface, ceiling or wall, will safely support the combined weight of all attached equipment and hardware. Video Mount Products will not be held liable for the improper use or installation of its products.**