

WMP

VIDEO MOUNT PRODUCTS

Instruction Sheet For:

AP-1

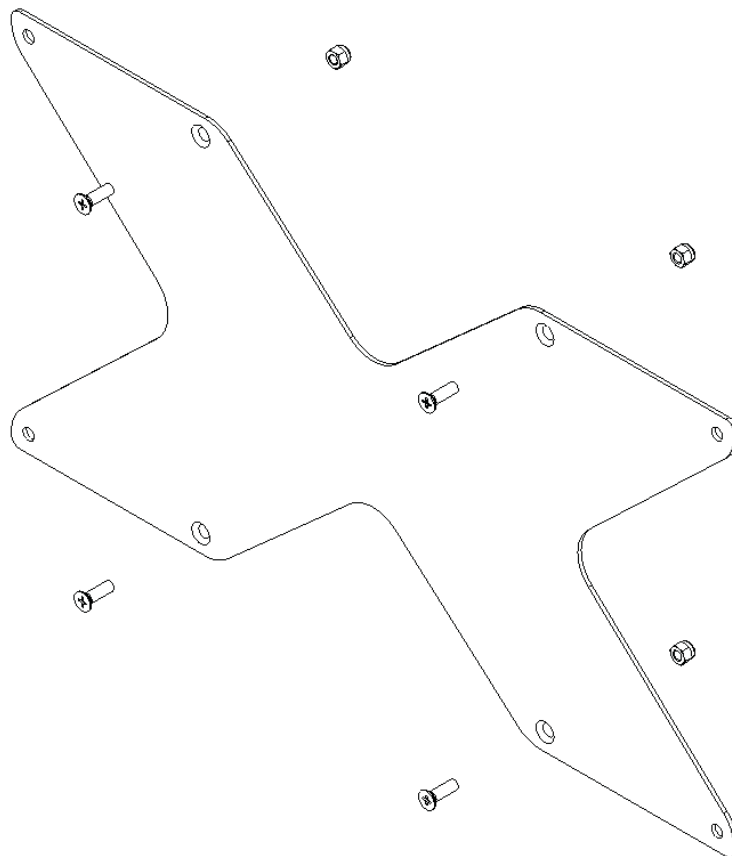

For more information, please contact us at:
345 Log Canoe Circle, Stevensville, Maryland 21666
Toll Free: 877.281.2169 Phone: 410.643.6390 Fax: 410.643.6615
www.videomount.com

AP-1

ITEM NO.	DESCRIPTION	QTY.
1	400 x 200 Plate	1
2	Flat Head Screw M5*P0.8*L16	4
3	Nylon Nut M5*P0.8	4

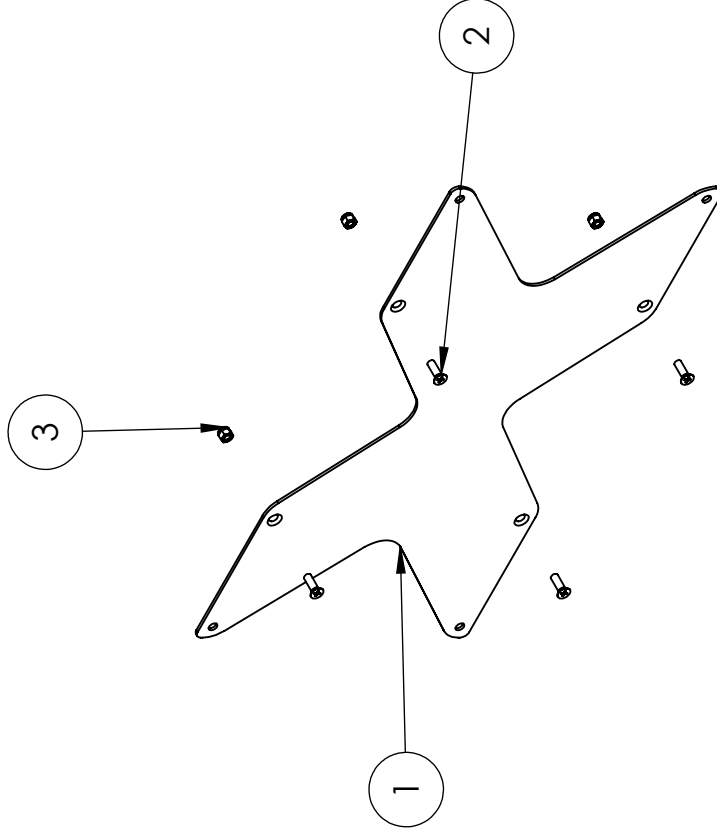

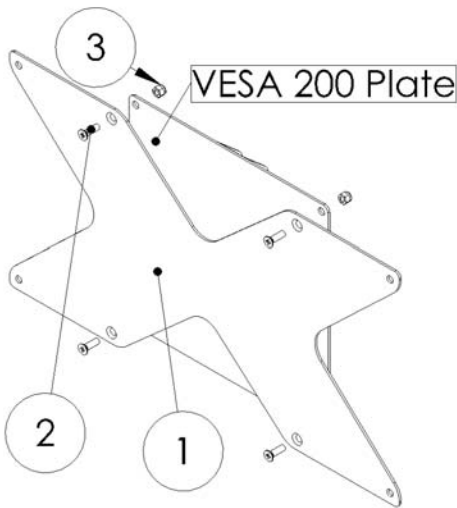

Step 2: Attaching the AP-1 to the mount

Step 1

Before starting, lay out all parts to your mount and match them to the parts list provided. Verify that you have all your parts before attempting to assemble the mount.

Note: For the purposes of these instructions it is assumed that you have already assembled the VESA 200 mount which you want to attach the AP-1 to. If you have not done so please proceed to do so at this time.

Step 2

Attach the AP-1 to the VESA 200 plate by inserting the flat head screws (2) into the countersink holes in the front of the AP-1 (1). Then use the nylon nuts (3) on the backside of the VESA 200 plate to secure the flat head screws (2).

Step 3

Attach the flat screen to the AP-1 (1) using the correct size screws that are provided with the VESA 200 mount.

Please verify that all nuts and screws are securely tightened.

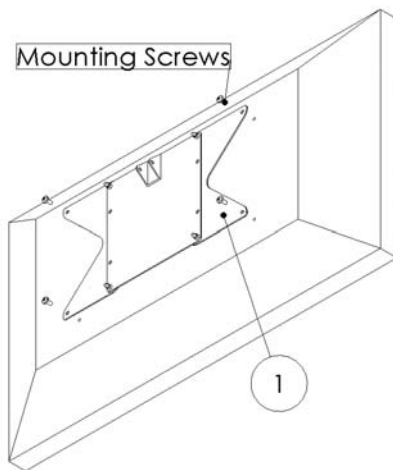

Step 3: Attaching the flat screen to the AP-1



Enjoy Your Mount!

WARNING: The installer of these products must verify that the mount surface, ceiling or wall, will safely support the combined weight of all attached equipment and hardware. Video Mount Products will not be held liable for the improper use or installation of its products.