

# DS-BP

FP-LDSB Wall Plate Extension

## Product Features:

Used w/ the FP-LDSB to extend the wall plate  
12" to add additional flat panels

Black powder coat finish

## Product Specifications:

*(for Architects & Engineers)*

The wall plate extension bridge plate for the Video Mount Products (VMP) part number FP-LDSB shall be the VMP part number DS-BP. The plate shall be able to extend the FP-LDSB wall plate 12" additional inches for every bridge plate added. The plate shall allow two or more FP-LDSB wall plates to connect together in a line. The plate shall incorporate welded screws and lock nuts. The plate shall be coated in a black finish.

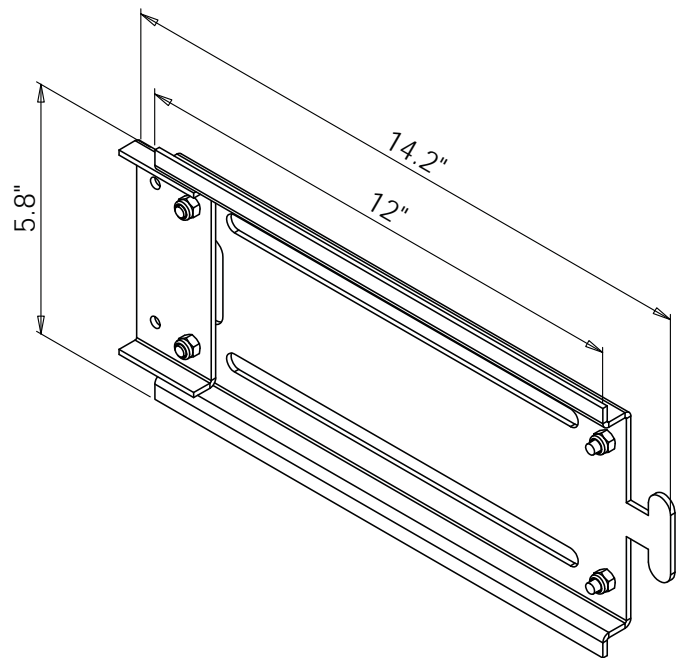

## Video Mount Products

345 Log Canoe Circle  
Stevensville, MD 21666  
Toll Free: 877.281.2169  
Telephone: 410.643.6390  
Facsimile: 410.643.6615  
[www.videomount.com](http://www.videomount.com)

**VMP**  
VIDEO MOUNT PRODUCTS