

ER-S1V

Vented Economy Rack Shelf

Product Features:

Fits components up to 17" wide

Two space racking height (2.6")

Tray depth - 12.5"

Includes 10-32 and 12-24 mounting screws

Load capacity – 40 lbs

Black powder coat finish

Product Specifications:

(for Architects & Engineers)

The vented equipment rack shelf shall be the Video Mount Products (VMP) model ER-S1V. The shelf shall be compatible with standard 19" equipment racks without modification. The shelf shall fit all components up to 17" in width. The shelf shall be painted with a durable black powder coat finish. The load capacity shall be 40 lbs.

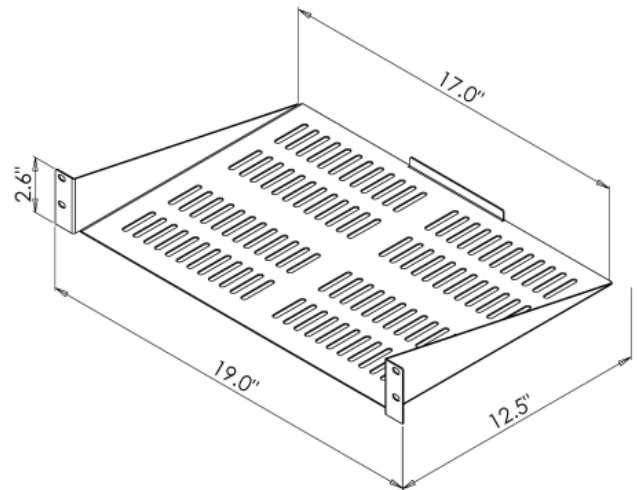

Video Mount Products

345 Log Canoe Circle

Stevensville, MD 21666

Toll Free: 877.281.2169

Telephone: 410.643.6390

Facsimile: 410.643.6615

www.videomount.com

