

WMP

VIDEO MOUNT PRODUCTS

Instruction Sheet For:

AK-1PT

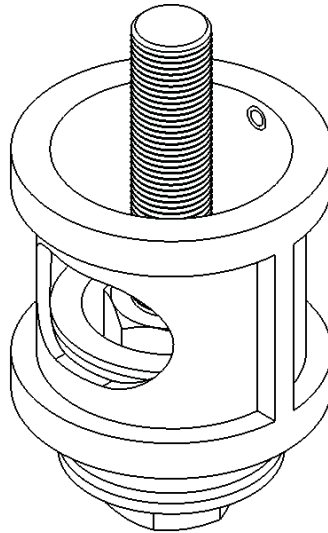

For more information, please contact us at:
345 Log Canoe Circle, Stevensville, Maryland 21666
Toll Free: 877.281.2169 Phone: 410.643.6390 Fax: 410.643.6615
www.videomount.com

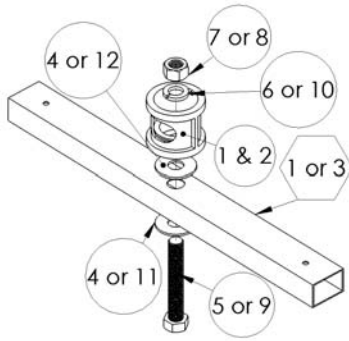

Step 3: Attaching the pipe couple to the force arm

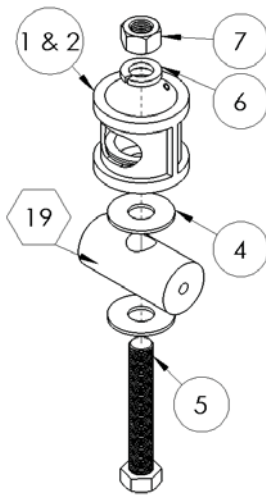

Step 4: Attaching the pipe couple to the connector

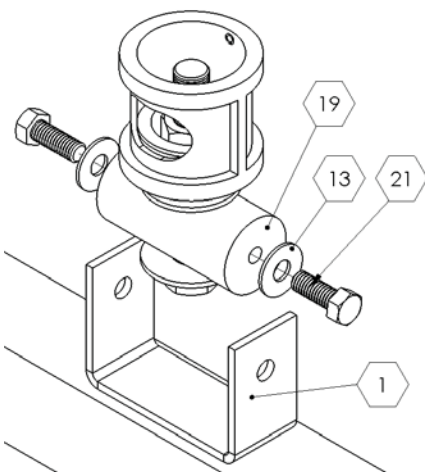

Step 5: Attaching the connector

Step 1

Before starting, lay out all parts to your mount and match them to the parts list provided. Verify that you have all your parts before attempting to assemble the mount. **Note: AK-1PT parts have circles around their part numbers while non-AK-1PT parts have hexagons.**

Step 2

The first step is to determine which mount you are attempting to use the AK-1PT with. **If you plan to use the AK-1PT with a VMP014/024, VMP042/044 or VMP046/048 proceed to step 3. If you plan to use the AK-1PT with a VMP036/038 proceed to step 4. If you plan to use an AK-1PT with a LCD-2537C or LCD-1C proceed to step 6. If you plan to use an AK-1PT with a PDM-C proceed to step 7. If you plan to use an AK-1PT with a PM-1 or PM-2 proceed to step 8. If you plan to use an AK-1PT with a PM-3 proceed to step 9.**

Step 3

Place a washer (4) or (11) on bottom of the center hole of your mount's force arm (1) VMP014/024 or (3) VMP042/044 or (3) VMP046/048. and either a plastic bushing (12) or washer (4) AK-1PT) **Note: The washers (4) are used for the VMP014/024 and the plastic bushing (12) and smaller washer (11) are used for the VMP042/044 and VMP046/048.** Insert the hex head screw (5) or (9) into the washers (4) or plastic bushing and washer (12) and (11) and center hole of the force arm (1) VMP014/024 or (3) VMP042/044 or (3) VMP046/048. Place the female pipe couple (1) and (2) on top of the hex head screw (5) or (9) and use the hex nut (7) or (8) and spring washer (6) or (10) to secure the couple to the force arm (1) VMP014/024 or (3) VMP042/044 or (3) VMP046/048. **Once finished proceed to step 11.**

Step 4

Place a washer (4) on the top and bottom of the large center hole in the connector (19) VMP036/038. Insert the 5/8" screw (5) through the washers and connector. Place the female pipe couple (1) and (2) on top of the 5/8" screw (5) and secure the couple to the connector (19) VMP036/038 using a spring washer (6) and hex nut (7).

Step 5

Attach the connector (19) VMP036/038 to the force arm (1) VMP036/038 using the 3/8" screws (21) VMP036/038 and making sure that the washers (13) VMP036/038 are between the uprights on the force arm (1) VMP036/038 and the connector (19) VMP036/038. **Once finished proceed to step 11.**

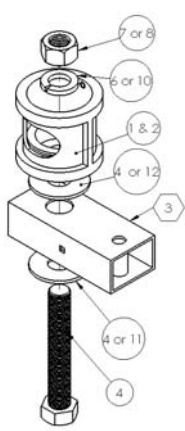

Step 6: Connecting the pipe couple to the support tube

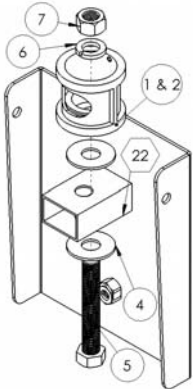

Step 7: Attaching the swivel bracket to the pipe couple

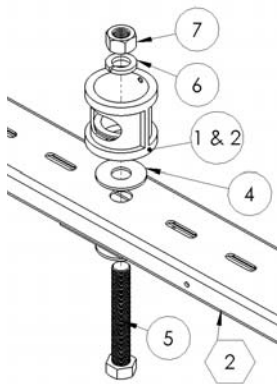

Step 8: Attaching the couple to the master support

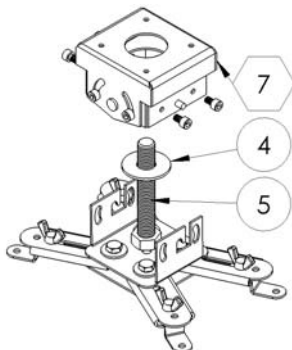

Step 9: Inserting the hex head screw into the projector assembly

Step 6

Place a washer (4) or (11) on bottom of the center hole of your mount's force arm (3) LCD-2537C and LCD-1C. and either a plastic bushing (12) or washer (4). **Note: The washers (4) are used for the LCD-2537C and the plastic bushing (12) and smaller washer (11) are used for the LCD-1C.** Insert the hex head screw (5) or (9) through the support tube and washers. Secure the female pipe couple (1) & (2) to the top of the support tube using the spring washer (6) or (10) and hex nut (7) or (8). **Once finished proceed to step 11.**

Step 7

Place a washer (4) on top and bottom of the welded square tubing in the inside of the swivel bracket B (22) PDM-C. Insert the 5/8" screw (5) through the square tubing and washers. Secure the female pipe couple (1) and (2) to the top of the square tubing using the spring washer (6) and hex nut (7). **Once finished proceed to step 11.**

Step 8

Place a washer (4) on top and bottom of the center hole in the master support (2) PM-1 or PM-2. Insert the 5/8" screw (5) through the master support and washers. Secure the female pipe couple (1) and (2) to the top of the master support using the spring washer (6) and hex nut (7). **Once finished proceed to step 11.**

Step 9

First you must disassemble the projector assembly (7) PM-3. Do this by removing the hex head cap screws in the side of the mount where there are "J" shaped cuts. Once this is done lift off the top of the assembly. Now place a washer (4) on the bottom of the hole in the top of the mount and insert the 5/8" screw (5) through the washer and the hole. Once this is accomplished reassemble the projector assembly.

Step 10

Now place a washer (4) on top of the 5/8" screw (5). Attach the female pipe couple (1) and (2) to the top of the mount using the spring washer (6) and hex nut (7). **Once finished proceed to step 11.**

Step 10: Attaching the couple to the projector assembly

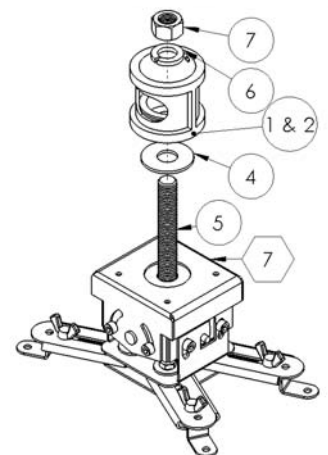

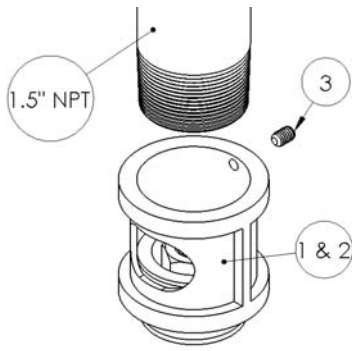

Step 11: Connecting the NPT pipe

Step 11

To connect the 1.5" NPT to the female pipe couple (1) and (2), screw one end into the top of couple and tighten the brake screw (3) to prevent the pipe from turning in the couple.

Step 12

Mark the ceiling or desired mounting surface in preparation of installation of the CP-1. Pre-drill if necessary and mount the CP-1 to desired surface.

Warning: Please verify that your mounting surface will support the combined weight of your mount, mounting hardware, and monitor. Also verify that the mounting surface is safe to drill through. If in doubt, please contact a professional installer.

Step 13

To connect the 1.5" NPT to the female pipe couple in the center of the CP-1, simply screw one end into the couple and tighten the brake screw to prevent the pipe from turning in the couple.

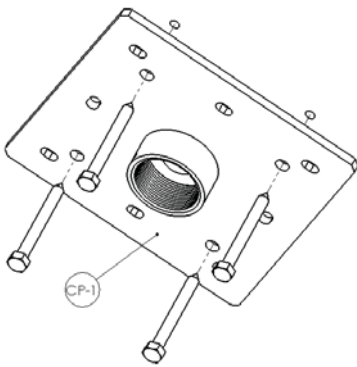

Step 12: Mounting the ceiling plate

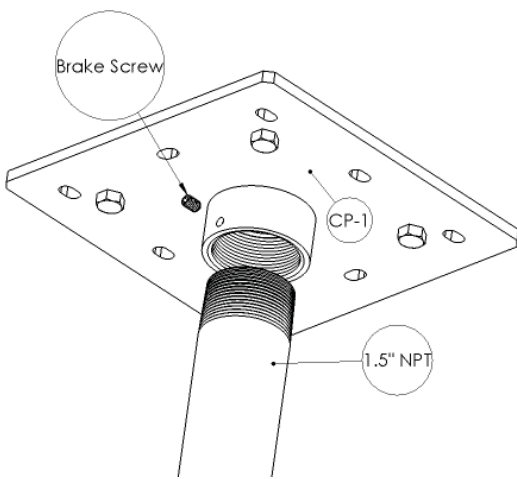

Step 13: Connect the pipe to the plate



Enjoy Your Mount!

WARNING: The installer of these products must verify that the mounting surface, ceiling or wall, will safely support the combined weight of all attached equipment and hardware. Video Mount Products will not be held liable for the improper use or installation of its products.